

# Data sheet 100C45.5-53

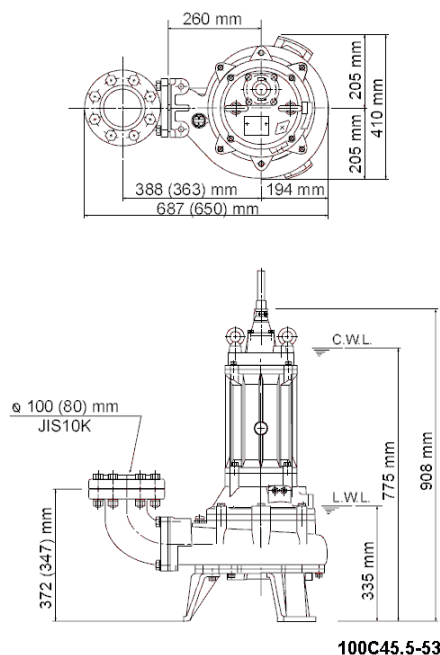

CWL: Continuous running water level  
LWL: Lowest running water level

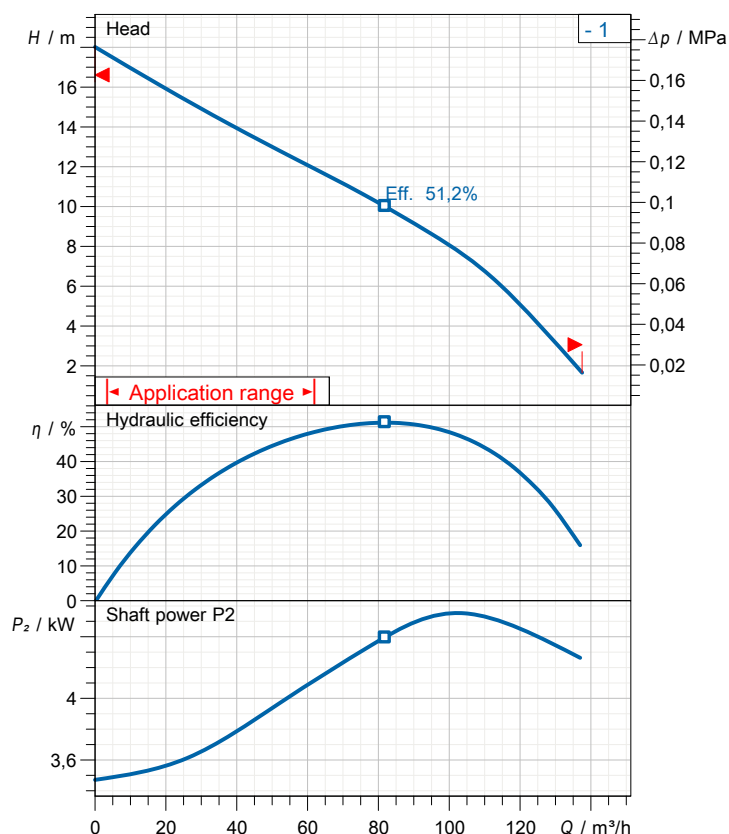

## Specification

Elektrische Tauchpumpe C-Serie  
Degree of protection IP 68  
Pressure resistance max. 15 m  
Type of impeller single channel impeller  
Free passage 40 mm  
Suitable for:  
sewage water and liquids carrying solids

## Electric motor

Dry-type submersible induction motor  
Insulation class F 4Poles 1443 1/min  
Starting mode Direct starting  
Rated voltage 400 V 50 Hz 3~  
Power uptake 6,92 kW  
Rated power 5,50 kW  
Rated current 12,1 A  
Start current 63,0 A

## Cable

10m H07RN-F 4Cx2,5mm<sup>2</sup>

## Motor Protection

Miniature protector in windings  
(snap-action bi-metal device)

## Shaft seal

Double inside mechanical seal in oil bath  
additional lubrication by oil lifting device  
Primary seal  
Silicon carbide on silicon carbide  
Secondary seal  
Silicon carbide on silicon carbide

## Bearings

Shielded ball bearings, maintenance-free

## Materials

Impeller  
FC20 (EN-GJL-200) + Tungsten carbide  
Pump casing FC200 (EN-GJL-200)  
Suction cover FCD700 (EN-GJS-700-2)  
Motor Frame FC200 (EN-GJL-200)  
Shaft SUS403 (EN-X6Cr13)

## Discharge size

4" (100mm) JIS 10K screwed-in mating flange  
guide rail fitting optional

## Weight

140 kg (dry weight of the pump only without cable)

# Performance curve

## 100C45.5-53

Discharge port	4"
FördH	18,0 m
Flow	137,5 m³/h
Rated power	5,50 kW
Power input	6,92 kW
Phases	3~
Voltages	400 V
Frequency	50 Hz
Rated current	12,1 A
Starting current	63,04 A
Number of poles	4
Speed	1443 1/min
Starting mode	Direct starting
Insulation class	F

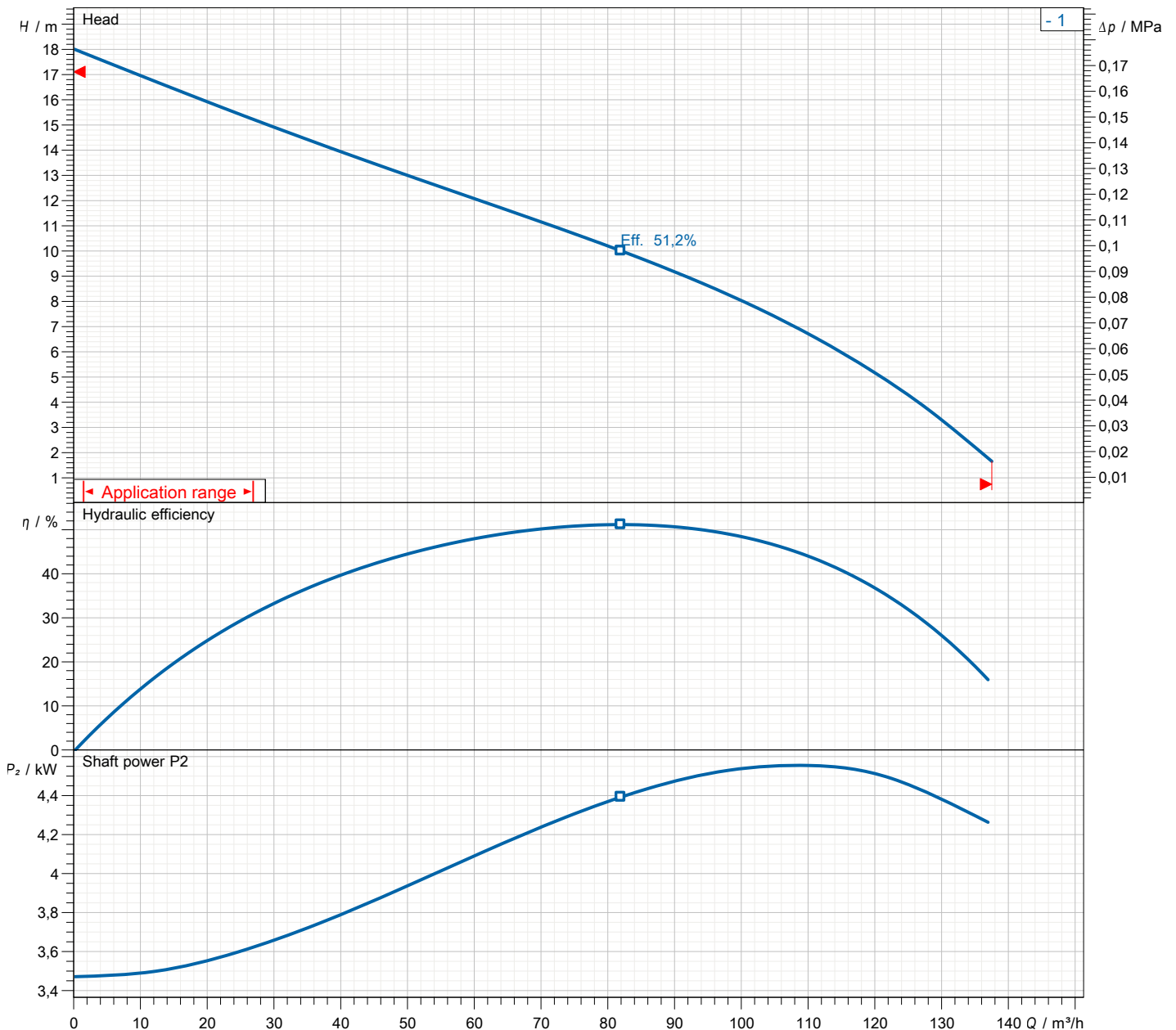

# Dimensions

## 100C45.5-53

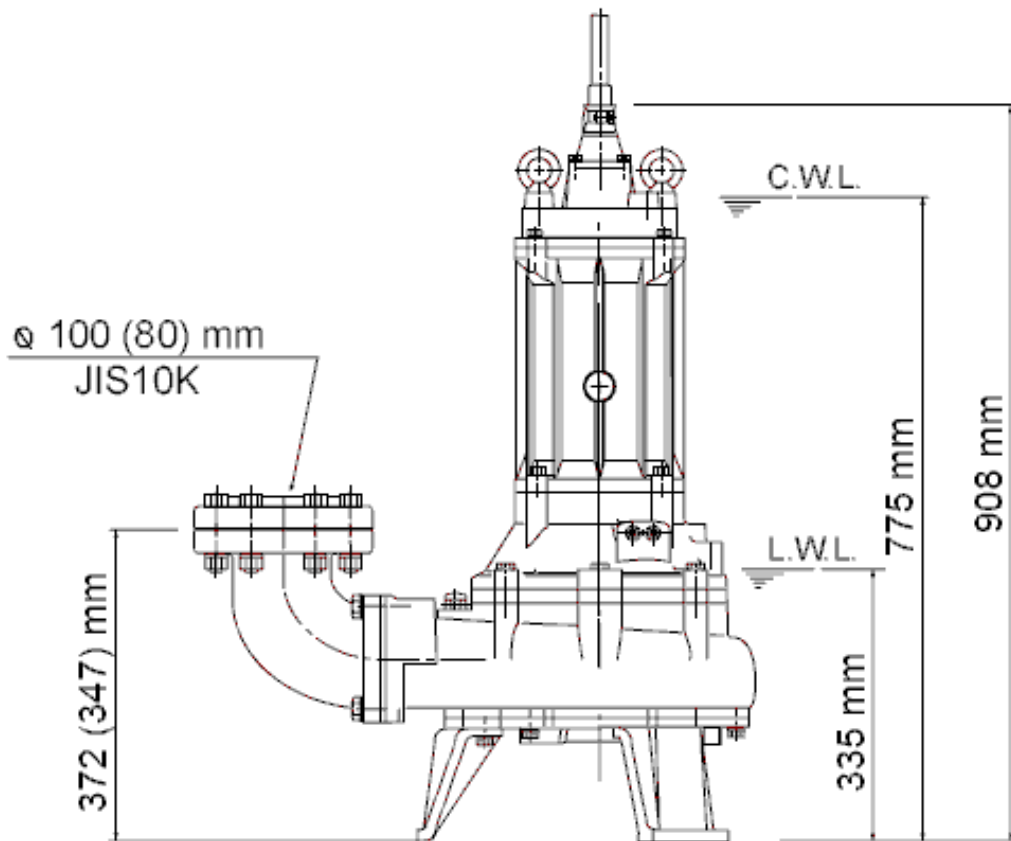
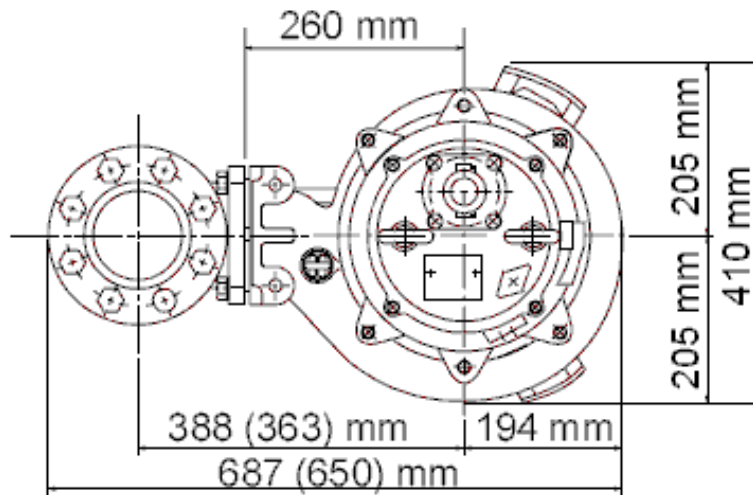

**100C45.5-53**

CWL: Continuous running water level  
LWL: Lowest running water level

# Sectional drawing 100C45.5-53

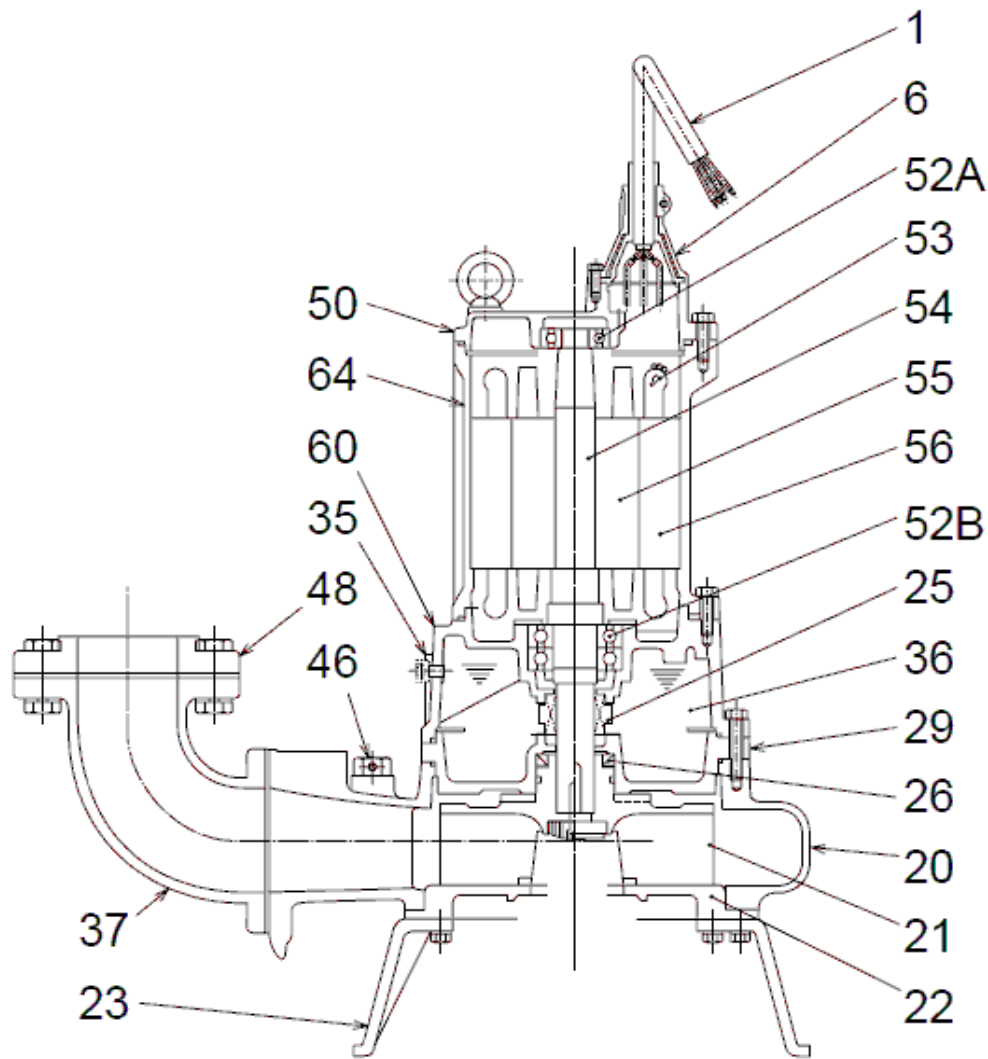

**100C45.5-52**

No.	Description	Remark	No.	Description	Remark
1	Cable (3x)	H07RN-F / 2PNCT-F	52B	Lower Bearing	6310ZZD2C3
6	Stuffing box	FC200 (EN-GJL-200)	53	Motor Protector 380/400/415V-50Hz	KA314-HRXL00 (H.C)
20	Pump casing	FC200 (EN-GJL-200)	54	Shaft	SUS403 (EN-X6Cr13)
21	Impeller	FC20 (EN-GJL-200) + Tungsten carbide	55	Rotor	.
22	Suction cover	FCD700 (EN-GJS-700-2)	56	0--	.
23	Stand support (3x)	FC200 (EN-GJL-200)	60	Bearing Housing	FC200 (EN-GJL-200)
25	Mechanical seal	H-40	64	Motor Frame	FC200 (EN-GJL-200)
26	Oil seal	TC709212	72	Eye screw (2x)	Construction steel SS400
29	Oil casing	FC200 (EN-GJL-200)			
35	Oil screw (2x)	SUS304 (EN-X5CrNi18-10)			
36	Lubricant	Turbine oil (ISO VG32)			
37	Discharge bend	FC200 (EN-GJL-200)			
46	Air vent screw	Nylon			
48	Screwed Flange	FC200 (EN-GJL-200)			
50	Motor cover	FC200 (EN-GJL-200)			
52A	Upper bearing	6306ZZC3			